



<p>F-6096A a x n°4/5 x n°1</p>	<p>F-6096B b x n°4/5</p>	<p>F-6096D d x n°4/8</p>	<ul style="list-style-type: none"> - I Prima di iniziare il montaggio, identificare tutti i componenti con l'aiuto delle istruzioni. - GB Before starting to assembly, please identify all components . - D Vor der montage, sind die Einzelteile anhand der Montageanleitung zu identifizieren. - F Avant de débuter le montage, identifiez tous les composants a l'aide de la notice. - E Antes de iniciar el montaje, identifique todos los componentes con ayuda de la nota.
------------------------------------	------------------------------	------------------------------	---

1 CS/6096-4A
CS/6096-5A
CS/6096-6A

Attenzione-Attention-Vorsicht-Attention-Atención

- I Si consiglia di effettuare il montaggio su una superficie morbida.
- GB It is a good idea to use a soft protective underlay during assembly.
- D Möbelteile auf eine weiche Oberfläche legen und dann aufstellen.
- F Veuillez poser les pièces sur un surface souple pour l'assemblage.
- E Se aconseja efectuar el montaje sobre una superficie blanda.

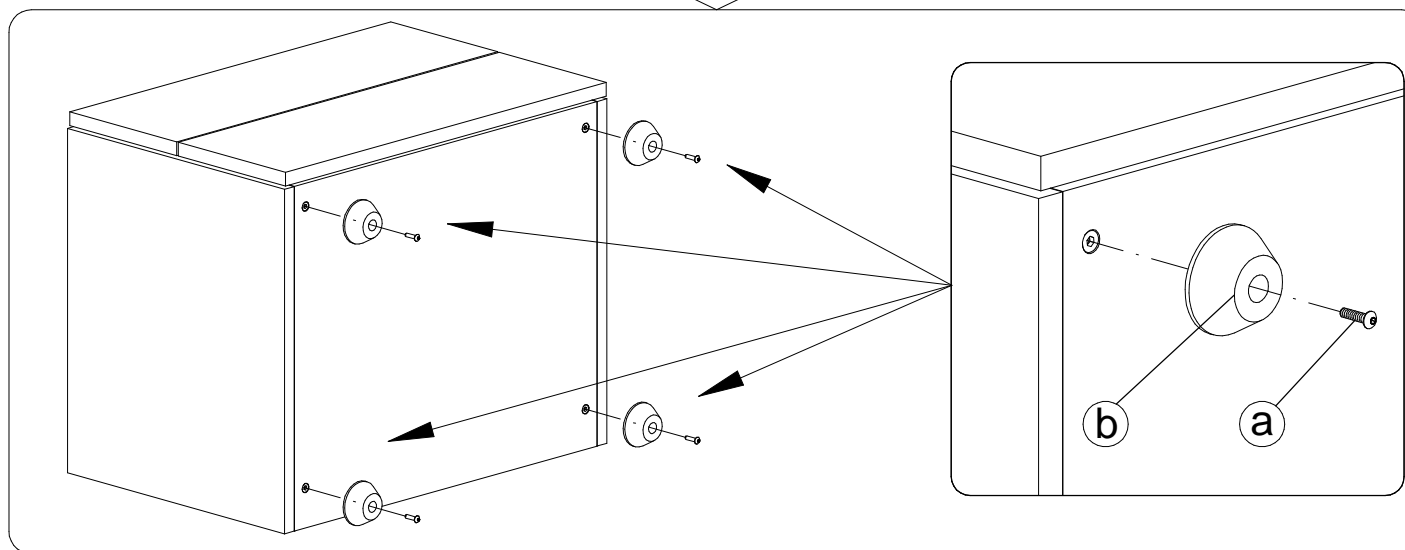
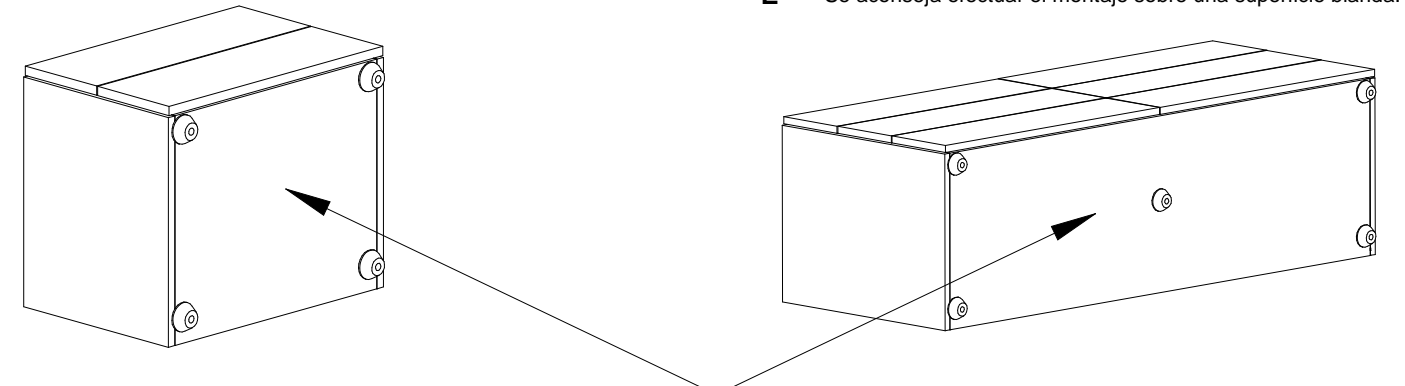

COMPANY WITH
MANAGEMENT SYSTEM
CERTIFIED BY DNV
ISO 9001 • ISO 14001



Calligaris S.p.A.
Via Trieste, 12
33044 Manzano - (UD) Italy
Tel. +39 0432 748211
calligaris.com

calligaris

H-A 6096 02.00

1 CS/6096-4B
CS/6096-6B

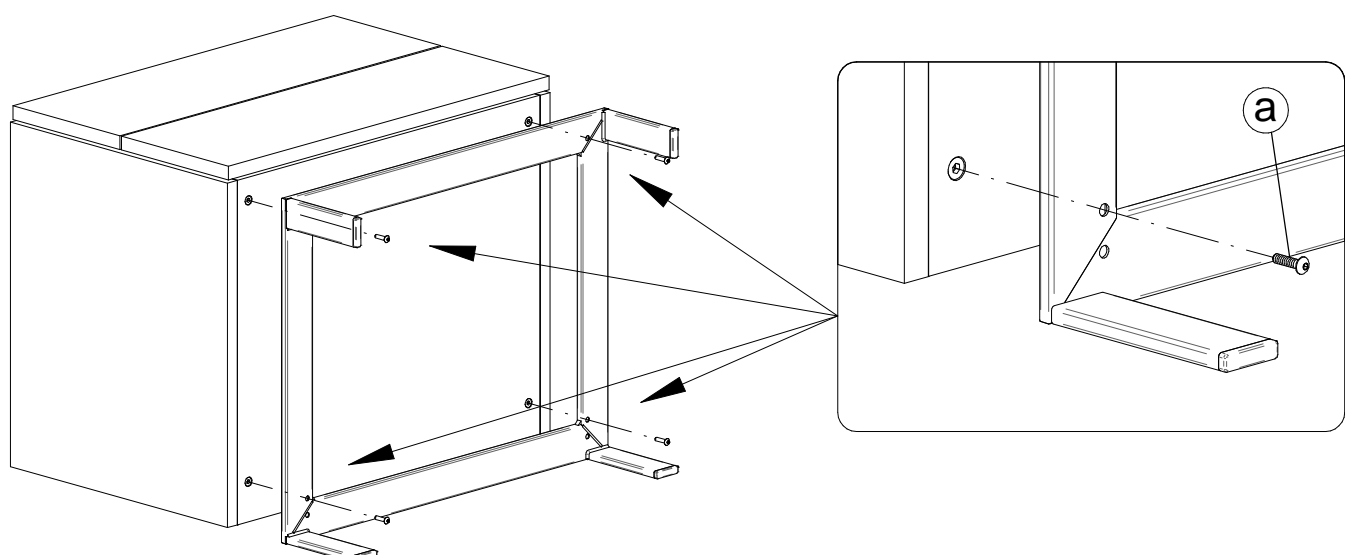
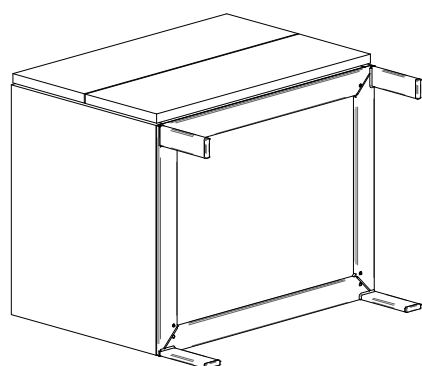

1 CS/6096-5B

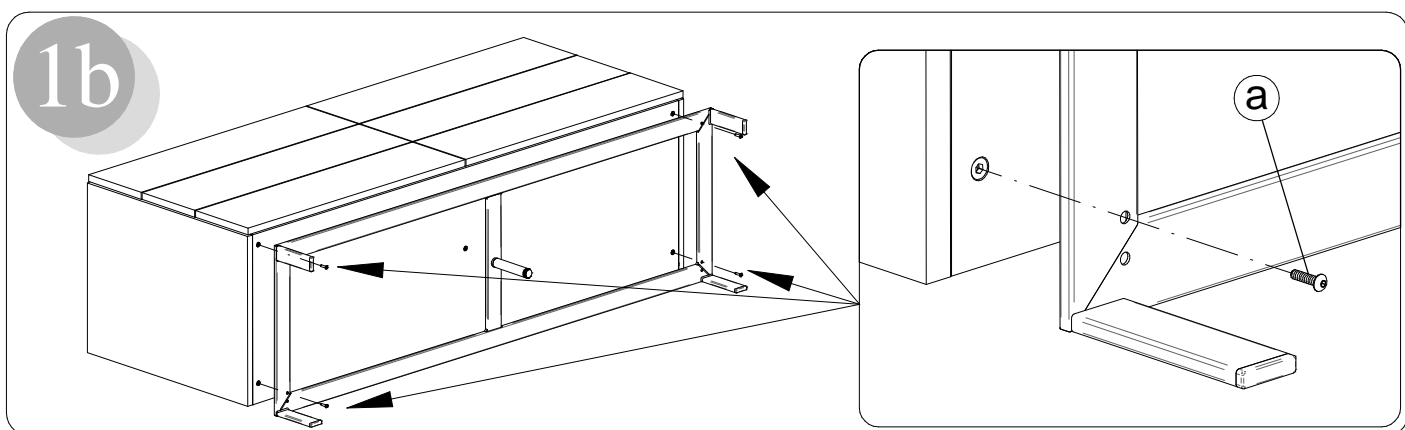
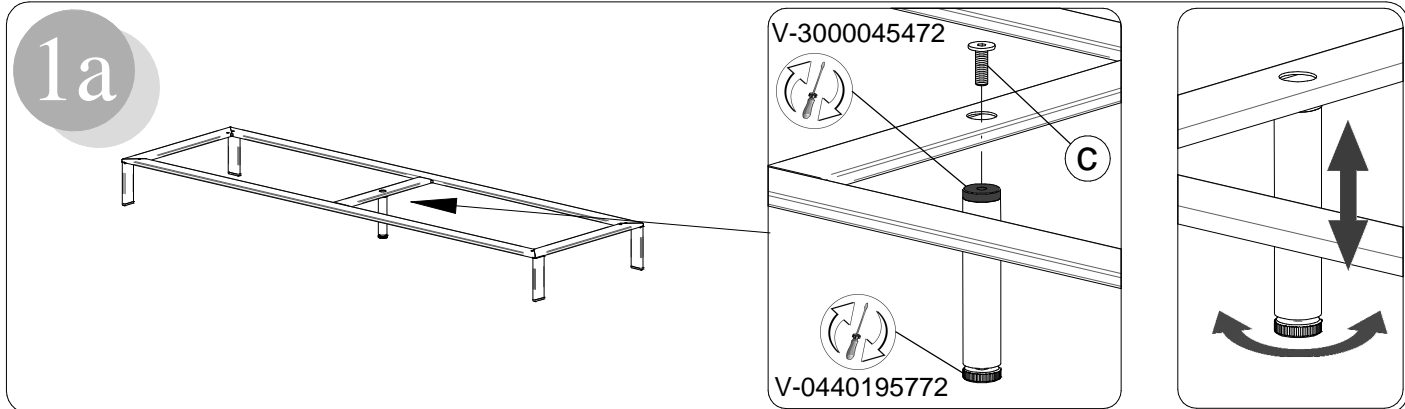
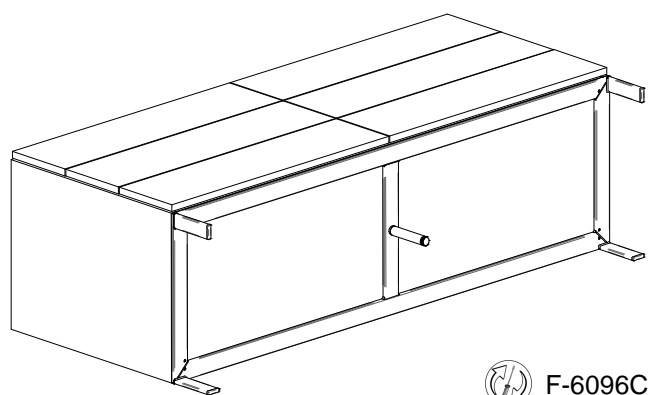

- I Pezzo di ricambio.
 - GB Spare part.
 - D Ersatzteil.
 - F Pièce en échange / s.a.v.
 - E Repuesto
- F-6096C
C x n°1 x n°1

2A

- I Top in ceramica su vetro float temprato
- GB Top ceramic on tempered float glass
- D Tischplatte Keramik auf gehärtetem Float-Glas
- F Plateau céramique sur verre float trempé
- E Encimera cerámica sobre el cristal float templado

2B

- I Top legno
- GB Wooden top
- D Holzplatte
- F Plateau en bois
- E Tapa de madera

V-0380440107

V-0380420107 DX
V-0380430107 SX

CS/6096-4...
CS/6096-6...

CS/6096-5...

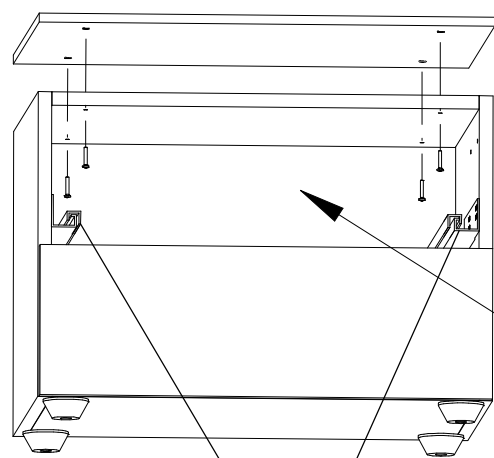

V-0380440107

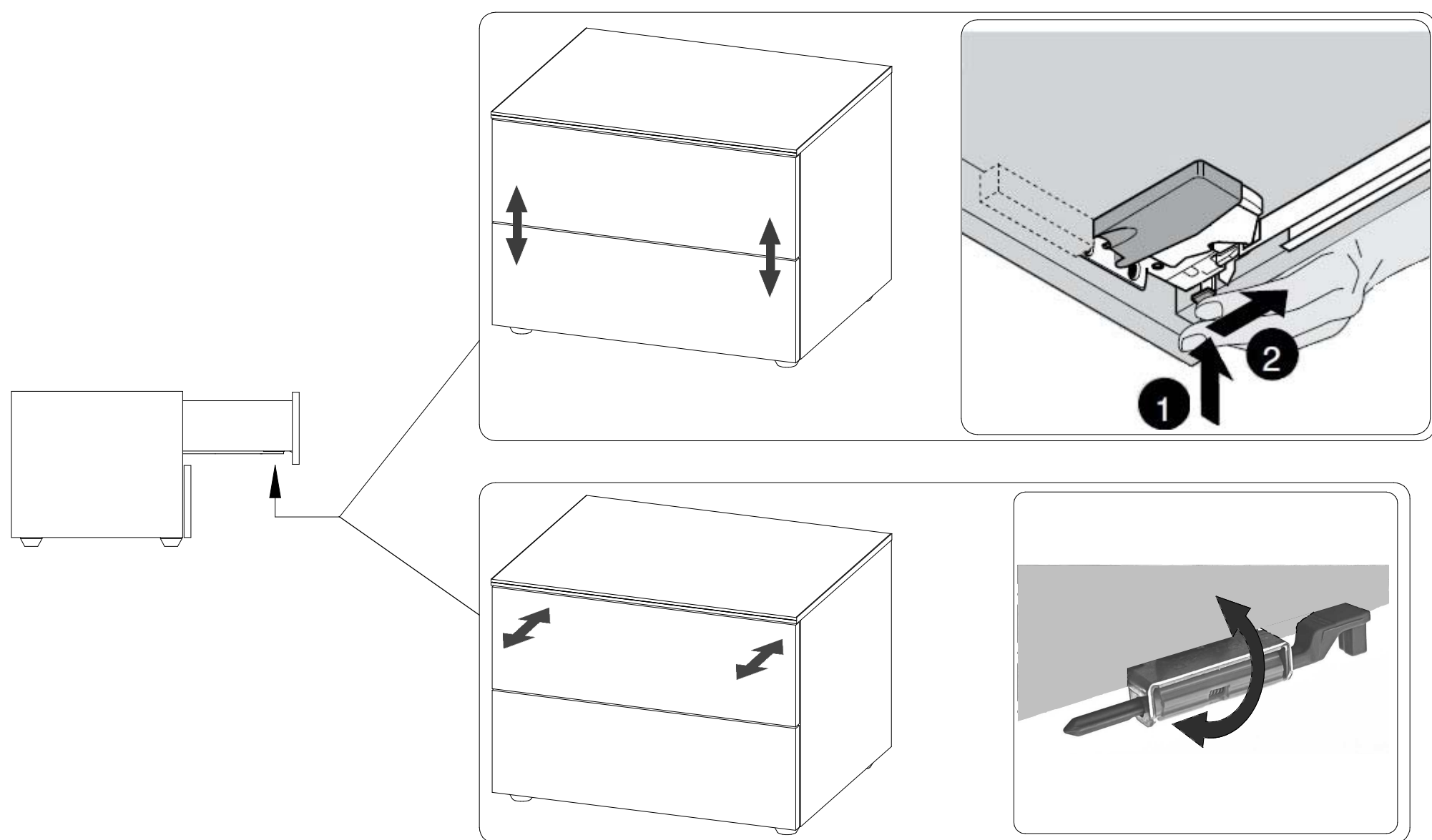
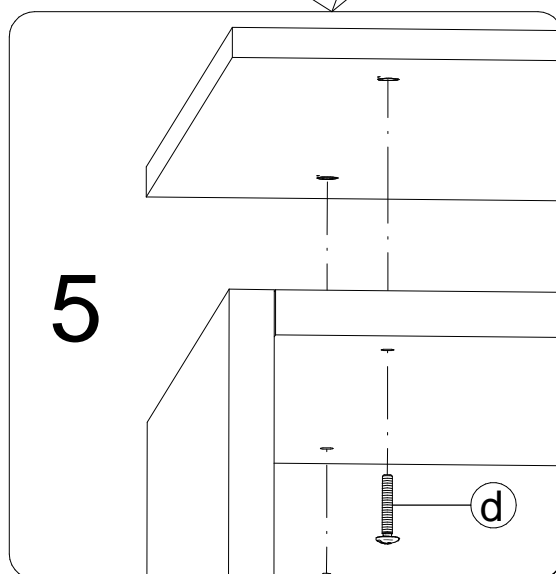
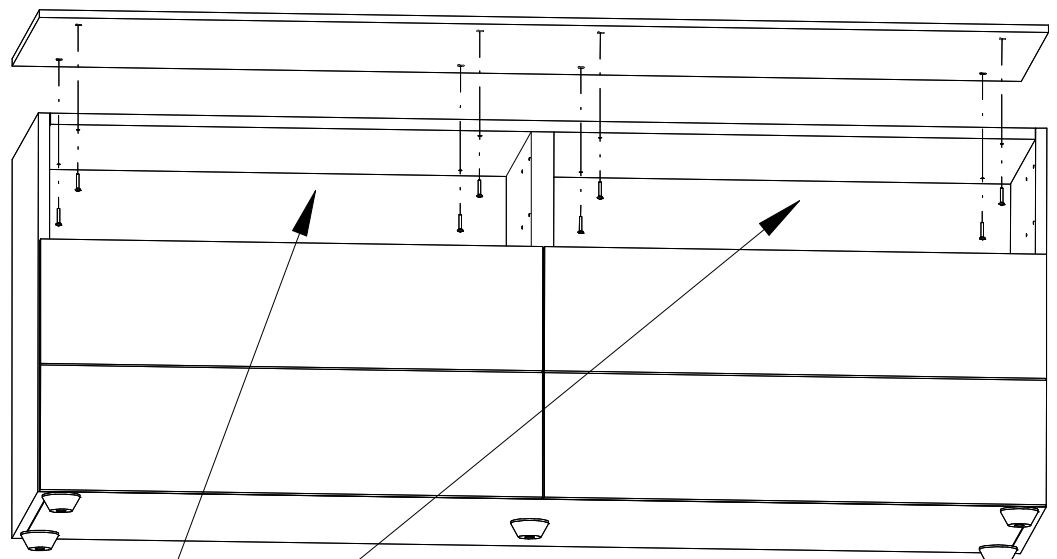

COMUNICAZIONI AL CLIENTE	CUSTOMER INFORMATION	MITTEILUNG AN DIE KUNDEN	COMMUNICATIONS AU CLIENT	COMUNICACIONES AL CLIENTE
<p>LA PRESENTE SCHEDA PRODOTTO DEVE ESSERE CONSEGNATA AL CLIENTE UNITAMENTE ALLA MERCE ACQUISTATA</p> <p>Mobile: 'Universal' Modello: CS6096 Materiali</p> <p>Struttura in particelle di legno a bassa emissione di formaldeide in conformità alle normative europee classe E1 e alle normative USA, nobilitata</p> <p>Oppure</p> <p>Struttura in MDF a bassa emissione di formaldeide in conformità alle normative europee classe E1 e alle normative USA, rivestita in legno verniciato</p> <p>Oppure</p> <p>Struttura in particelle di legno a bassa emissione di formaldeide in conformità alle normative europee classe E1 e alle normative USA, nobilitata e verniciata</p> <p>Parti in materiale plastico Istruzioni d'uso</p> <p>Al fine di garantire la stabilità e la durata nel tempo dell'articolo, si consiglia di verificare periodicamente il corretto serraggio delle viterie</p> <p>Carico massimo applicabile uniformemente distribuito sul piano: 20 kg</p> <p>Carico massimo applicabile uniformemente distribuito in ogni cassetto: 12 kg</p> <p>Il prodotto non è adatto ad uso esterno</p> <p>Il contatto delle superfici del prodotto con corpi caldi può danneggiare il materiale</p> <p>Per interventi di straordinaria manutenzione o di riparazione rivolgersi al rivenditore di fiducia</p> <p>Una volta dismessi il prodotto od i suoi componenti non vanno dispersi nell'ambiente, ma conferiti ai sistemi pubblici di smaltimento rifiuti</p> <p>Consigli di manutenzione</p> <p>I liquidi rovesciati devono essere assorbiti immediatamente con un panno pulito e asciutto</p> <p>Per la pulizia delle parti in legno, utilizzare esclusivamente prodotti specifici</p> <p>ATTENZIONE! Per garantire la durata del prodotto pulire le parti in plastica utilizzando solo acqua tiepida e sapone neutro. Evitare assolutamente l'uso di alcool etilico o di detersivi contenenti, anche in piccole quantità, acetone, trielina e ammoniaca e solventi in generale. Non usare sgrassatori universali.</p> <p>Non usare prodotti abrasivi La Calligaris S.p.a. declina ogni responsabilità derivante da un uso improprio dell'oggetto sopra descritto</p>	<p>THIS PRODUCT LIST MUST BE DELIVERED TO THE CUSTOMER TOGETHER WITH THE PURCHASED MATERIAL</p> <p>Cabinet: 'Universal' Model: CS6096 Materials</p> <p>Structure made of wooden chipboard with low formaldehyde emission, in compliance with European standards, melaminated</p> <p>Or</p> <p>Structure made of MDF with low formaldehyde emission, in compliance with European standards and USA standards, covered with lacquered wood</p> <p>Or</p> <p>Structure made of wooden chipboard with low formaldehyde emission, in compliance with E1 class European standards and USA standards, melaminated and painted</p> <p>Parts in plastic material User instructions</p> <p>In order to guarantee stability and life of the article, periodically check that the screws are correctly tightened</p> <p>Maximum weight bearing on the top (with equally distributed weight): 20 kg</p> <p>Maximum weight bearing on each drawer (with equally distributed weight): 12 kg</p> <p>The product is not suitable for outdoor use</p> <p>Contact with hot items can damage the surface</p> <p>For major maintenance or repairs, consult the retailer</p> <p>Once the product or its components are no longer used, make sure that they are disposed of correctly through the public waste disposal services</p> <p>Maintenance recommendations</p> <p>Any spills should be wiped up immediately with a clean, dry cloth</p> <p>To clean wooden parts, use products that are specifically for wood</p> <p>ATTENTION! In order to guarantee product durability, clean the plastic elements by using lukewarm water and neutral soap only. Do not use ethyl alcohol or detergents that contain even small amounts of acetone, trichloroethylene or ammonia or solvents in general. Do not use any universal degreaser.</p> <p>Do not use abrasive products Calligaris S.p.a. disclaims any responsibility deriving from incorrect use of the above mentioned object</p>	<p>DIE VORLIEGENDE KARTE MIT DEN TECHNISCHEN DATEN DES PRODUKTS IST DEM KUNDEN ZUSAMMEN MIT DEM EINGEKkauFTEN PRODUKT ZU ÜBERGEBEN</p> <p>Möbelstück: 'Universal' Modell: CS6096 Materialien</p> <p>Gestell aus Holzspänen mit niedrigen Formaldehydausstoßwerten gemäß den Europäischen Vorschriften Klasse E1 und allen us-amerikanischen Vorschriften, melaminbeschichtet</p> <p>Oder</p> <p>Gestell aus MDF mit niedrigen Formaldehydausstoßwerten gemäß den Europäischen Vorschriften Klasse E1, und den amerikanischen Vorschriften, Holz furniert, gebeizt</p> <p>Oder</p> <p>Gestell aus Holzspänen mit niedrigen Formaldehydausstoßwerten gemäß den Europäischen Vorschriften Klasse E1, und allen us-amerikanischen Vorschriften, melaminbeschichtet und lackiert</p> <p>Teile aus Kunststoff Gebrauchsanweisung</p> <p>Zur Gewährleistung der Stabilität und der Beständigkeit des Artikels, ist die regelmäßige Prüfung der korrekten Schraubenbefestigung ratsam</p> <p>Maximale Tragfähigkeit bei verteiltem Gewicht: 20 kg</p> <p>Maximale Tragfähigkeit der Schublade bei verteiltem Gewicht: 12 kg</p> <p>Das Produkt ist für die Außenanwendung nicht geeignet</p> <p>Um Schäden vorzubeugen, verhindern Sie bitte den Kontakt der Oberflächen mit heißen Gegenständen</p> <p>Wenden Sie sich für außerordentliche Wartungsarbeiten oder Reparaturen an den Händler Ihres Vertrauens</p> <p>Wenn das Produkt oder seine Komponenten keine Verwendung mehr findet, dann muß es entsprechend über öffentliche Müllsysteme entsorgt werden</p> <p>Wartungshinweise</p> <p>Verschüttete Flüssigkeiten müssen sofort mit einem sauberen und trockenen Tuch entfernt werden</p> <p>Verwenden Sie zur Reinigung der Holzteile ausschließlich Produkte, die speziell für Holz geeignet sind</p> <p>ACHTUNG! Um die Beständigkeit, des Produktes zu gewährleisten, reinigen Sie die Plastikteile bitte ausschließlich mit warmem Wasser und neutraler Seife.</p> <p>Kein Aceton, Trichloräthylen, Ammoniak und Alkohol verwenden, weil sie die Oberfläche angreifen.</p> <p>Ebenfalls abschleifende Reinigungsmittel, wie beispielsweise Pulver oder Paste und raue Tücher vermeiden. Verwenden Sie bitte keine Universal-Reiniger und -Entfetter.</p> <p>Benutzen Sie keine Schleifmittel Die Calligaris S.p.a. übernimmt keine Haftung bei unsachgemäßem Gebrauch des Produkts</p>	<p>LA FICHE PRODUIT DOIT ÊTRE REMISE AU CLIENT AVEC LA MARCHANDISE</p> <p>Meuble: 'Universal' Modèle: CS6096 Matériaux</p> <p>Structure en bois aggloméré à émission limitée de formaldéhyde conformément aux normes européennes classe E1 et aux normes américaines, plaquée en bois verni</p> <p>Ou</p> <p>Structure en MDF à émission limitée de formaldéhyde conformément aux normes européennes classe E1 et aux normes américaines, plaquée en bois verni</p> <p>Ou</p> <p>Structure en bois aggloméré à émission limitée de formaldéhyde conformément aux normes européennes E1 et normes USA, mélaminée et peinte</p> <p>Parties en matériel plastique Instructions</p> <p>Afin de garantir la stabilité et la durée de l'article il est conseillé de vérifier périodiquement le serrage des vis</p> <p>Poids maximal applicable à distribuer uniformément sur le plateau: 20 kg</p> <p>Poids maximal applicable à distribuer uniformément dans chaque tiroir: 12 kg</p> <p>Le produit n'est pas prévu pour l'extérieur</p> <p>Le contact de la surface du dessus avec des corps chauds peut endommager le matériel</p> <p>Pour toute intervention d'entretien extraordinaire ou de réparation, contacter le revendeur</p> <p>A la fin de son utilisation, le produit ou ses éléments ne doivent pas être abandonnés dans l'environnement, mais déposés auprès des centres de traitement et d'élimination des déchets</p> <p>Conseils d'entretien</p> <p>Les liquides renversés doivent être absorbés immédiatement avec un chiffon propre et sec</p> <p>Pour le nettoyage des parties en bois, utiliser exclusivement des produits spécifiques pour le bois</p> <p>ATTENTION! Pour garantir la longévité du produit, nettoyez les parties en plastique avec de l'eau tiède et du savon doux.</p> <p>Éviter absolument l'usage d'alcool éthylique ou de détergents contenant même en petite quantité acétone trichloréthylène et ammoniaque et dissolvants en général. Ne pas utiliser dégraissants universels.</p> <p>Ne pas utiliser des produits abrasifs Calligaris S.p.a. décline toute responsabilité en cas d'utilisation erronée de l'objet indiqué ci-dessus</p>	<p>LA FICHA DE PRODUCTO DEBE ENVIARSE AL CLIENTE JUNTO A LA MERCANCIA</p> <p>Mueble: 'Universal' Modelo: CS6096 Materiales</p> <p>Estructura de partículas de madera de baja emisión de formaldehído en conformidad con la normativa europea clase E1 y con las normativas USA, refinada</p> <p>O</p> <p>Estructura en MDF de baja emisión de formaldehído en conformidad con la normativa europea clase E1 y con las normativas USA, revestida en madera barnizada</p> <p>O</p> <p>Estructura de partículas de madera de baja emisión de formaldehído en conformidad con la normativa europea clase E1 y con las normativas USA, ennoblecida y barnizada</p> <p>Partes en material plástico Instrucciones de uso</p> <p>Al fin de garantizar la estabilidad y la duración en el tiempo del artículo, se aconseja controlar periódicamente que los tornillos sean correctamente apretados</p> <p>Peso máximo aplicable distribuido uniformemente sobre el plano: 20 kg</p> <p>Peso máximo aplicable distribuido uniformemente en cada cajón: 12 kg</p> <p>El producto no es apto para el uso en exteriores</p> <p>El contacto de la superficie del producto con cuerpos calientes puede degenerar el material</p> <p>En caso de reparaciones o de mantenimiento extraordinario dirigirse al comercio vendedor</p> <p>Cuando se desee el producto utilizar los canales apropiados</p> <p>Consejos de mantenimiento</p> <p>Los líquidos derramados deben ser absorbidos inmediatamente con un paño limpio y seco</p> <p>Para la limpieza de las partes de madera, utilizar exclusivamente productos específicos para la madera</p> <p>CUIDADO! Para garantizar la duración del producto limpiar las partes en plástico utilizando sólo agua tibia y jabón neutro. Hay que evitar el uso de acetone, tricloroetileno y amoniaco o detergentes que contengan cualquier cantidad, por pequeña que sea, de estas sustancias, que atacan los plásticos. También conviene evitar el alcohol etílico, porque si no está muy diluido en agua puede volver opacas las superficies. No utilizar desengrasantes universales.</p> <p>No usar productos abrasivos Calligaris S.p.a. declina toda responsabilidad derivada de una utilización inapropiada de los objetos arriba descritos</p>